

CONTROLLING FABRIC BULK IN PLEATED SWAGS AND JABOTS

STEP 1 Cut the jabot interlining with the same grain you cut the face and lining fabric. Cut the swag lining and interlining on the bias, even if you cut the face fabric upright.

STEP 2 Place the interlining against the wrong side of the lining. Pin all sides. Machine baste the interlining to the lining about 1" to 2" below the board line in the pleat or gathered areas. Trim the interlining close to the stitching. This will eliminate bulk from the top of the board later.

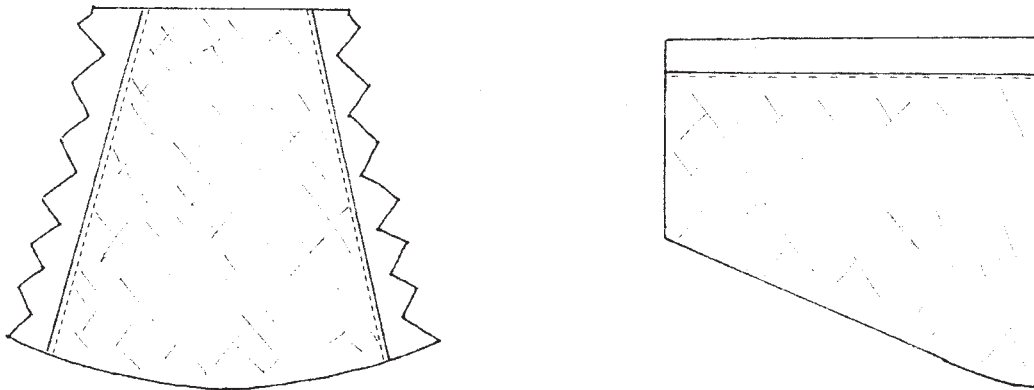

STEP 3 Place the right side of the lining against the right side of the face fabric, stitch across the bottom of the swag. Stitch across the top also if it is a pole swag. Stitch the side and bottom of the jabot, leaving the top open. Trim the interlining close to the stitching at these seams.

STEP 4 Trim the seams according to the pattern directions, turn the fabric right side out. The interlining should now be between the lining and the face fabric.

STEP 5 Continue to make the item according to the pattern instruction book.



You can eliminate even more fabric bulk if you trim away the lining after it has been stitched to the item at the board line. This means that pleated swags would have to be stitched at the zigzag areas before pleating is done.